



Cuadra-Soft

Patricia Urquiola, 2025

Cuadra-Soft was born from the desire to combine two fundamental dimensions: a specific idea of comfort with a shape capable of expressing the archetype underlying the design intuition.

The essentiality of the composition is combined with generous volumes designed to accommodate. The soft, rounded contours follow the armrests and the Seater, while the diagonally sloping legs break up the static nature and give rhythm and lightness to the structure.

AI generated image

CUADRA-SOFT
Patricia Urquiola 2025

PRODUCT SHEET
Last updated: april 2026

Carlo Scarpa monograph
Charlotte Perriand monograph

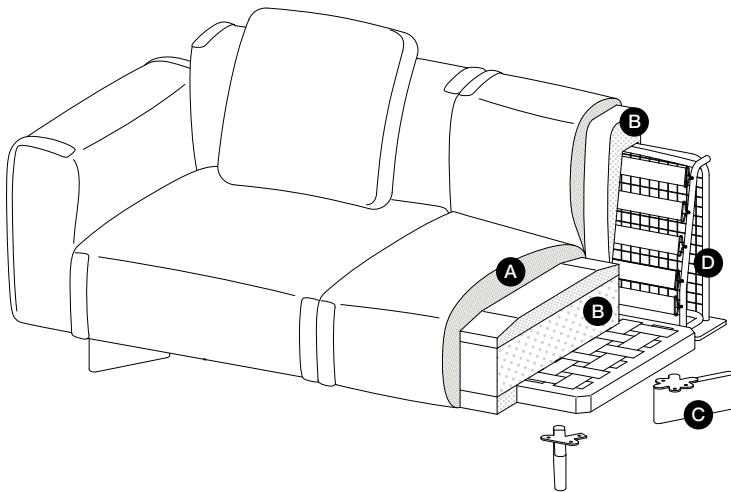

- A** Padded quilting with recycled polyester fiber
- B** Polyurethane foam with differentiated densities
- C** Varnished solid ash or Lacquered beech feet
- D** Tubular steel frame with elastic webbing
- E** Support foot

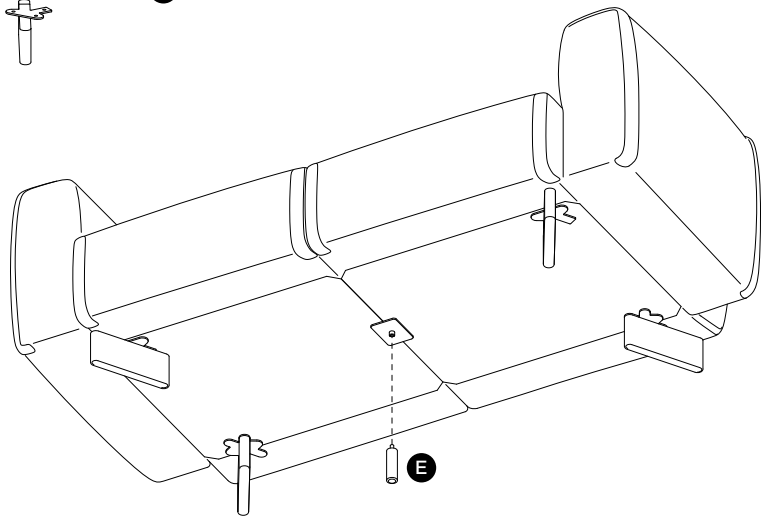

Seater Structure	Seater cushion in flexible polyurethane with differentiated densities and recycled polyester fiber. Frame in powder-coated tubular steel with elastic webbing.
Backrest & Armrest Structure	Backrest and armrests feature a steel frame and elastic webbing, covered with a differentiated-density polyurethane cap and a quilted layer padded with recycled polyester fiber.
Base	Feet, fixed to the Seater frame, are in varnished solid ash wood; the lacquered version is in beech. See finish table on page 10.
Upholstery	The Cuadra-Soft collection covers are fully removable. For recommended fabrics see table on pages 8-9.
Composability	Cuadra soft is a system that includes sofas and modular elements to create compositions.

Moroso reserves the right to modify any design and change any technical specifications of any product at any time without prior notice. The drawings do not define the product details; the dimensions reported are indicative and may be subject to change.

CS0002

2-Seater sofa

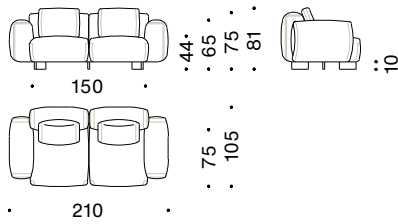

CS0018

2-Seater major sofa

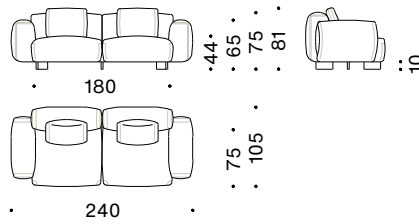

CS0003

3-Seater sofa

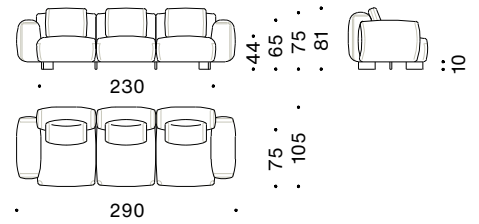

CS0CM1

3-Seater major sofa

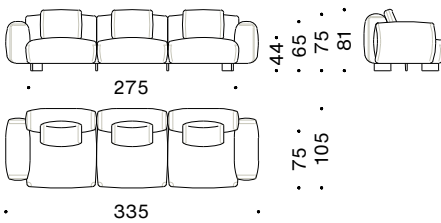

CS007A*

2-Seater central element

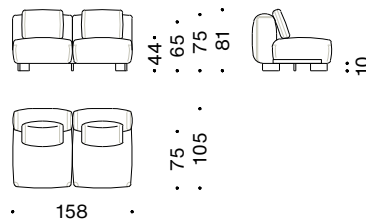

CS00M5*

2-Seater major central element

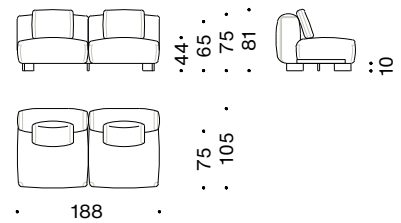

CS00M4*

3-Seater major central element

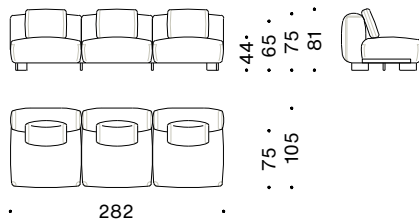

CS0023*

2-Seater left end element

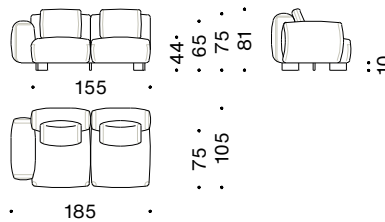

CS0022*

2-Seater right end element

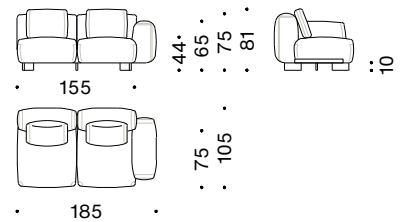

CS0037*

2-Seater major left end element

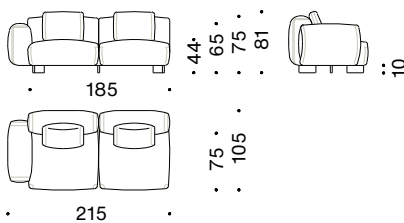

CS0031*

2-Seater major right end element

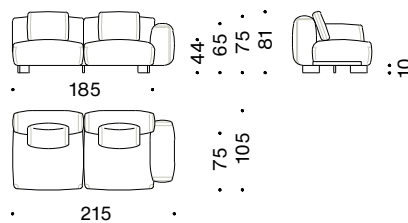

CS0033*

3-Seater left end element

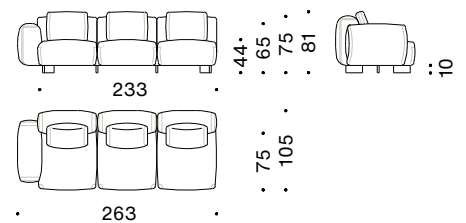

* Element for compositions only

Moroso reserves the right to modify any design and change any technical specifications of any product at any time without prior notice. The drawings do not define the product details; the dimensions reported are indicative and may be subject to change.

CS0032*

3-Seater right end element

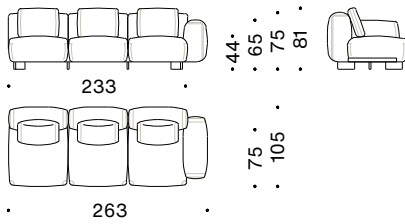

CS003S*

3-Seater major left end element

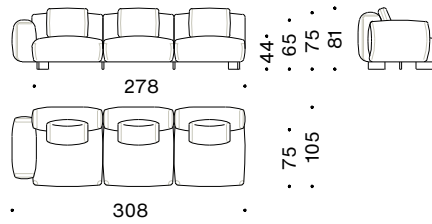

CS0030*

3-Seater major right end element

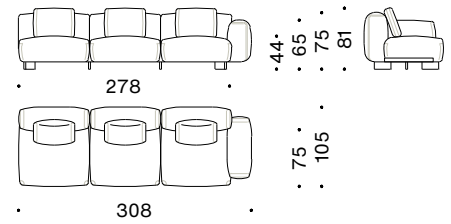

CS00GK

2-Seater right peninsula with armrest

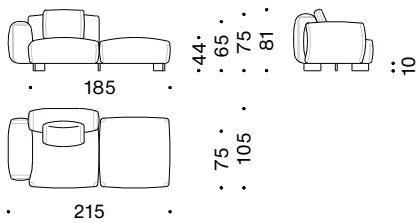

CS00GJ

2-Seater left peninsula with armrest

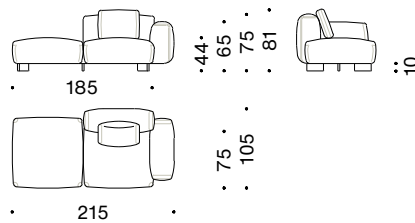

CS00TL*

2-Seater major right end peninsula

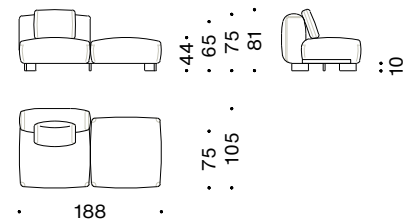

CS00TM*

2-Seater major left end peninsula

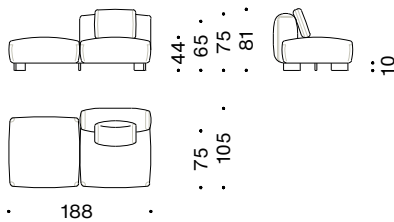

CS00GM

3-Seater major right peninsula with armrest

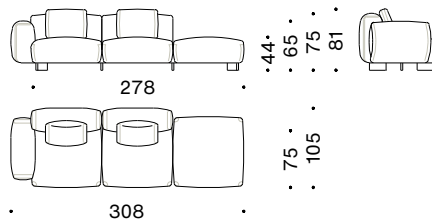

CS00GL

3-Seater major left peninsula with armrest

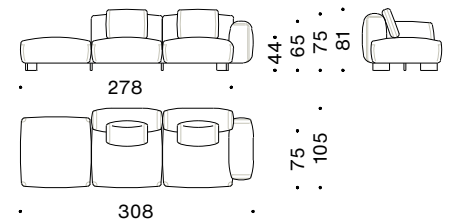

CS00TI*

3-Seater major left end peninsula

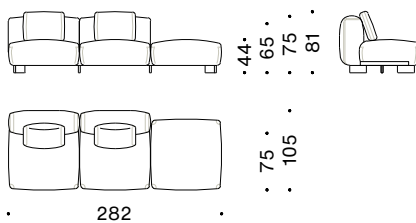

CS00TJ*

3-Seater major right end peninsula

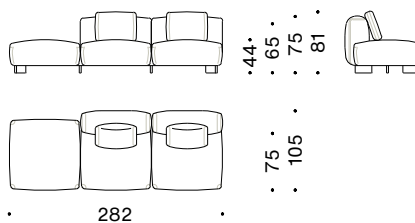

CS00M2*

2-Seater major left corner element

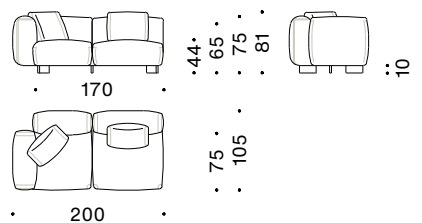

* Element for compositions only

Moroso reserves the right to modify any design and change any technical specifications of any product at any time without prior notice. The drawings do not define the product details; the dimensions reported are indicative and may be subject to change.

CS00M3*
2-Seater major right corner element

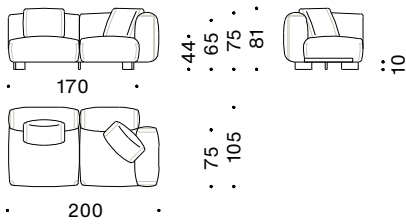

CS00MA*
2-Seater left corner element with peninsula

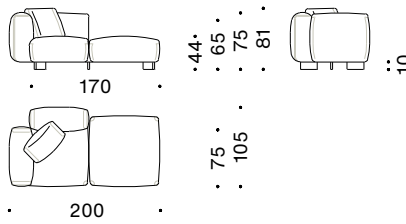

CS00MB*
2-Seater right corner element with peninsula

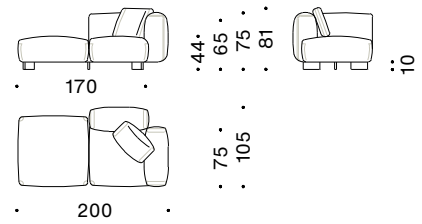

CS00D1*
2-Seater left corner element

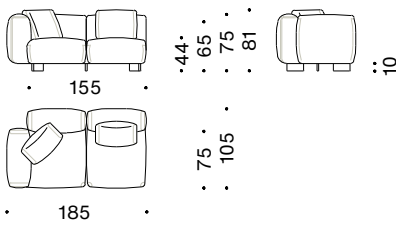

CS00D2*
2-Seater right corner element

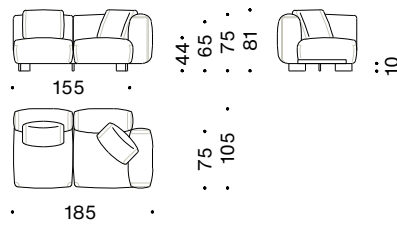

CS00MC*
3-Seater major left corner element

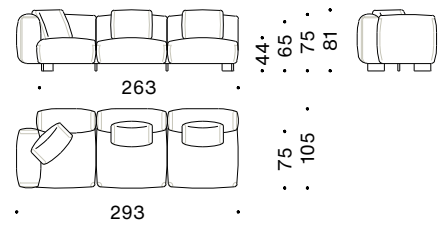

CS00MD*
3-Seater major right corner element

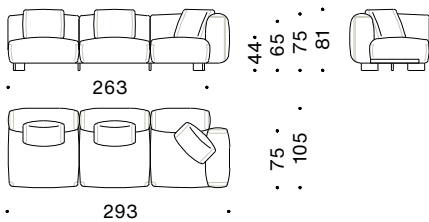

CS00MI*
3-Seater left corner element with peninsula

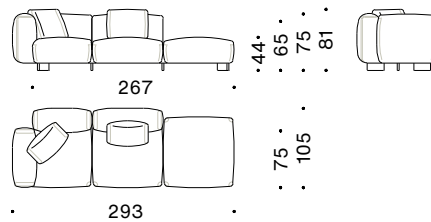

CS00MJ*
3-Seater right corner element with peninsula

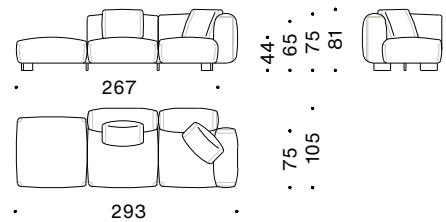

CS00MK*
3-Seater left corner element

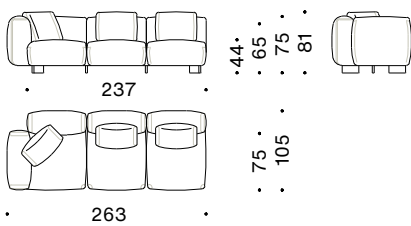

CS00MM*
3-Seater right corner element

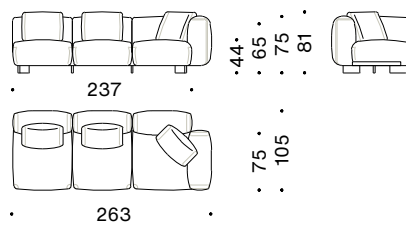

CS0956*
3-Seater left closed-end corner element

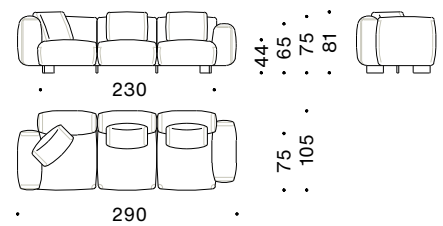

* Element for compositions only

Moroso reserves the right to modify any design and change any technical specifications of any product at any time without prior notice. The drawings do not define the product details; the dimensions reported are indicative and may be subject to change.

CS0957*

3-Seater right closed-end corner element

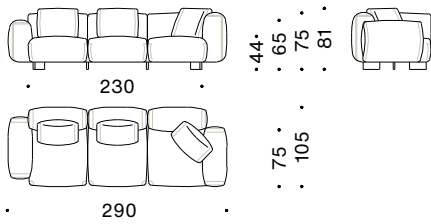

CS00ME*

3-Seater major left closed-end corner element

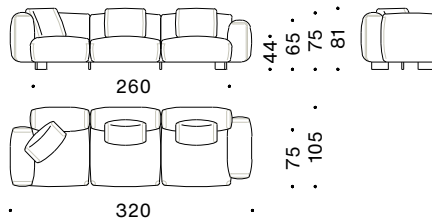

CS00MO*

3-Seater major right closed-end corner element

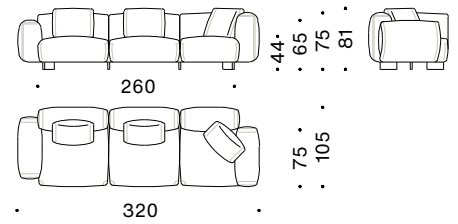

CS00D4*

Left chaise longue

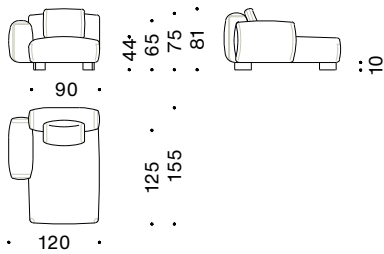

CS00D3*

Right chaise longue

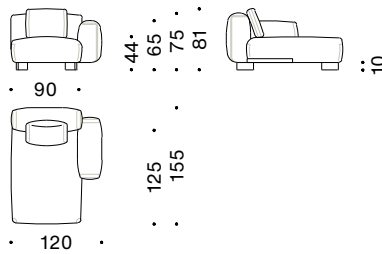

CS004S

Center chaise longue

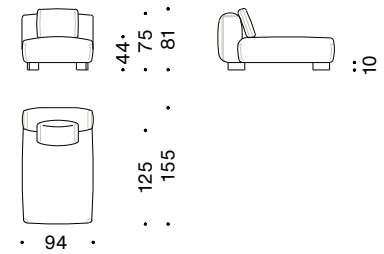

CS01D4*

Chaise Longue major left

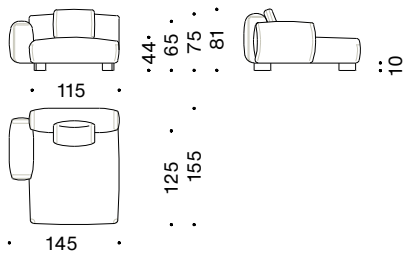

CS01D3*

Chaise Longue major right

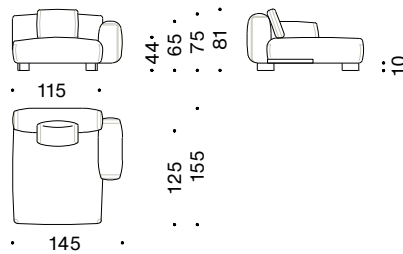

CS014S

Chaise Longue major central

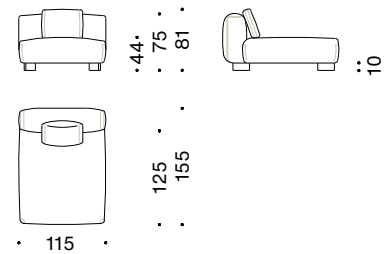

CS0444

Ottoman

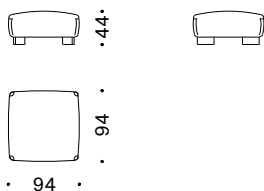

CS0017

Pouf

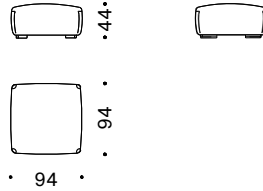

CS005P

Pillow

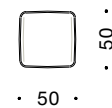

* Element for compositions only

Moroso reserves the right to modify any design and change any technical specifications of any product at any time without prior notice. The drawings do not define the product details; the dimensions reported are indicative and may be subject to change.

USAGE CATEGORIES

<p>S Soft Use Cosy and natural, with limited wear resistance</p> <p>ALAYA woven fabric DASDIA bouclé FURY chenille GUEST woven fabric PIUMA bouclé SASH woven fabric</p>	<p>M Medium Use Robust and durable, easy to maintain</p> <p>ARMAGH woven fabric BARNABY woven fabric FUZZY bouclé GORGONE bouclé KEMET woven fabric LHATI chenille</p>	<p>H Heavy Use High technical values, very robust and durable</p>
----------------------------------------------------------------------------------------------------------------------------------------------------------------------------------------------------------------------------------------------------------	--------------------------------------------------------------------------------------------------------------------------------------------------------------------------------------------------------------------------------------------------------	-------------------------------------------------------------------------------------

BOUCLÉS



S **DASDIA**

Typology: bouclé
Composition: 45% cotton, 16% viscose, 14% wool, 13% acrylic, 10% linen, 2% polyamide
Height: appr. 140 cm
Abrasion resistance: 35.000 cycles

CAT. **S**
Hanger: **TOPPINGS**
154 + 155

Check with your Moroso representative to evaluate modifications, additions and available colours. The use of customer own fabric is possible previous technical verification by the company.



M **FUZZY**

Typology: bouclé
Composition: 48% viscose, 36% wool, 13% cotton, 3% polyamide
Height: appr. 140 cm
Weight: 550 g/sqm
Abrasion resistance: 40.000 cycles
Colour fastness to artificial light: 6
Pilling resistance: 4-5

CAT. **W**
Hanger: **TOPPINGS**
154 + 155

Check with your Moroso representative to evaluate modifications, additions and available colours. The use of customer own fabric is possible previous technical verification by the company.



M **GORGONE**

Typology: elastic bouclé
Composition: 33% viscose, 28% acrylic, 14% wool, 9% cotton, 7% polyester, 6% linen, 2% polyamide, 1% elasthan
Height: appr. 148 cm
Weight: 860 g/sqm
Abrasion resistance: 60.000 cycles
Rubbing fastness: 4-5 (dry)
Colour fastness to artificial light: 5
Pilling resistance: 4

CAT. **W**
Hanger: **TOUCH ME**
158

Check with your Moroso representative to evaluate modifications, additions and available colours. The use of customer own fabric is possible previous technical verification by the company.

COVERS: Covers must be washed or cleaned according to the instructions reported on the product label. In case of stains, always contact an authorised centre. **DISPOSAL:** in order to respect the environment, it is recommended, at the end of the product's life, to separate the various component parts as much as possible and follow the respective recycling, recovery or disposal procedures in accordance with the regulations in force in the countries concerned.



S **PIUMA**
Typology: bouclé
Composition: 70% acrylic, 15% cotton, 15% polyester
Height: appr. 140 cm
Weight: 520 g/sqm
Abrasion resistance: 30.000 cycles
Rubbing fastness: 4 (dry)
Colour fastness to artificial light: 5/6
Pilling resistance: 4/5

CAT. S
Hanger: SARTORIAL 163

Check with your Moroso representative to evaluate modifications, additions and available colours. The use of customer own fabric is possible previous technical verification by the company.

WOVEN FABRICS



S **ALAYA**
Typology: woven fabric
Composition: 60% wool, 35% cotton, 5% polyester
Height: appr. 140 cm
Weight: 1050 g/sqm
Abrasion resistance: 25.000 cycles
Rubbing fastness: 4/5 (dry)
Colour fastness to artificial light: 5
Pilling resistance: 3/4

CAT. Y
Hanger: SARTORIAL 163

Check with your Moroso representative to evaluate modifications, additions and available colours. The use of customer own fabric is possible previous technical verification by the company.



M **ARMAGH**
Typology: woven fabric
Composition: 65% wool, 28% linen, 7% polyester
Height: appr. 140 cm
Abrasion resistance: 50.000 cycles
Rubbing fastness: 4/5 (dry)
Colour fastness to artificial light: 4
Pilling resistance: 4

CAT. W
Hanger: SARTORIAL 163

Check with your Moroso representative to evaluate modifications, additions and available colours. The use of customer own fabric is possible previous technical verification by the company.

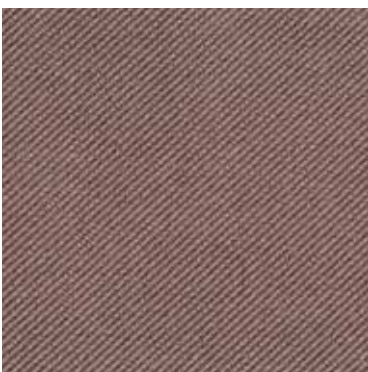

M **BARNABY**
Typology: woven fabric
Composition: 40% wool, 30% cotton, 30% viscose
Height: appr. 139 cm
Weight: 640 g/sqm
Abrasion resistance: 65.000 cycles

CAT. W
Hanger: SARTORIAL 163

Check with your Moroso representative to evaluate modifications, additions and available colours. The use of customer own fabric is possible previous technical verification by the company.

COVERS: Covers must be washed or cleaned according to the instructions reported on the product label. In case of stains, always contact an authorised centre. **DISPOSAL:** in order to respect the environment, it is recommended, at the end of the product's life, to separate the various component parts as much as possible and follow the respective recycling, recovery or disposal procedures in accordance with the regulations in force in the countries concerned.



S GUEST

Typology: woven fabric
Composition: 63% wool, 23% linen, 14% cotton
Height: appr. 140 cm
Weight: 1160 g/sqm
Abrasion resistance: 25.000 cycles
Rubbing fastness: 4/5 (dry)
Colour fastness to artificial light: 5
Pilling resistance: 3/4

CAT. **Z**
 Hanger: **SARTORIAL 163**

Check with your Moroso representative to evaluate modifications, additions and available colours. The use of customer own fabric is possible previous technical verification by the company.

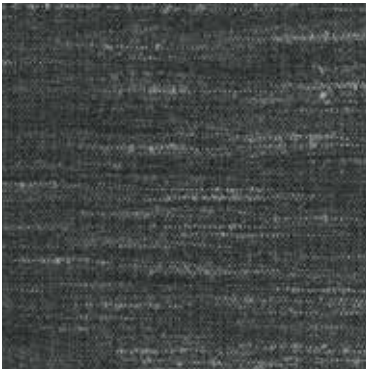

M KEMET

Typology: woven fabric
Composition: 34% cotton, 19% linen, 16% acrylic, 16% polyester, 15% wool
Height: appr. 140 cm
Weight: 660 g/sqm
Abrasion resistance: 55.000 cycles
Colour fastness to artificial light: 4/5
Pilling resistance: 4

CAT. **W**
 Hanger: **SARTORIAL 163**

Check with your Moroso representative to evaluate modifications, additions and available colours. The use of customer own fabric is possible previous technical verification by the company.



S SASH

Typology: woven fabric
Composition: 58% acrylic, 12% cotton, 12% linen, 12% viscose, 6% polyester
Height: appr. 140 cm
Weight: 745 g/mq
Abrasion resistance: 30.000 cycles
Rubbing fastness: 4 (dry)
Colour fastness to artificial light: 4/5
Pilling resistance: 3-4

CAT. **S**
 Hanger: **TOUCH ME 158**

Check with your Moroso representative to evaluate modifications, additions and available colours. The use of customer own fabric is possible previous technical verification by the company.

CHENILLES



M LHATI*

Typology: chenille
Composition: 36% acrylic, 35% polyester, 29% cotton
Height: approx. 140 cm
Weight: 800 g/sqm
Abrasion resistance: 50.000 cycles
Colour fastness to artificial light: 5/6
Pilling resistance: 4

CAT. **W**
 Hanger: **TOPPINGS + TOUCH ME 154 + 158**

* In the hanger Toppings 154 it is possible to use also the Fury fabrics.

Check with your Moroso representative to evaluate modifications, additions and available colours. The use of customer own fabric is possible previous technical verification by the company.

COVERS: Covers must be washed or cleaned according to the instructions reported on the product label. In case of stains, always contact an authorised centre. **DISPOSAL:** in order to respect the environment, it is recommended, at the end of the product's life, to separate the various component parts as much as possible and follow the respective recycling, recovery or disposal procedures in accordance with the regulations in force in the countries concerned.

Brushed Honey



Brushed Caffè



Brushed Nut Brown



LAQUERED BEECH WOOD FEET / VARIANTS

Sienna



Black

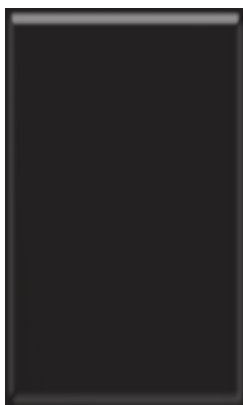

FINISHES: for any doubts or further information regarding care and cleaning, please contact your Moroso representative.

DISPOSAL: in order to respect the environment, it is recommended, at the end of the product's life, to separate the various component parts as much as possible and follow the respective recycling, recovery or disposal procedures in accordance with the regulations in force in the countries concerned.

Moroso Spa
via Nazionale 60
33010 Cavalioco, UD, Italy
T +39 0432 577 111
info@moroso.it

CUADRA-SOFT
Patricia Urquiola 2025

PRODUCT SHEET
Last updated: april 2026